

INSTALLATION INSTRUCTIONS

DESCRIPTION: Rear Brush Guard Kit

PART NUMBER: B4M-F85E0-V0

MODEL: 2021+ Wolverine R-Max2 and 2019+ Wolverine X2



⚠ WARNING

Please read and understand these instructions completely before installation to avoid possible injury, or damage to the accessory or vehicle.

WARRANTY INFORMATION:

In the United States, see your Yamaha dealer for a copy of the Yamaha Genuine Parts and Accessories Limited Warranty.

NOTICE:

Installation of this kit requires a torque wrench and should be performed by an authorized Yamaha dealer or a qualified mechanic.

DEALER OR INSTALLER:

These instructions contain important information for future reference and *must* be given to the customer.

PARTS LIST:

No.	Part Number	Description	Qty
--	B4M-F85E0-V0	Rear Brush Guard Kit	--
①	B4M-F845R-V0*	Carry Bar	1
②	B8K-F8426-V0*	Bracket Spacer	2
③	95812-08030*	M8x30 Flanged Bolt	4
④	B8K-F8436-V0*	Weld Nut Plate	2

* Part supplied with kit only and not available separately.

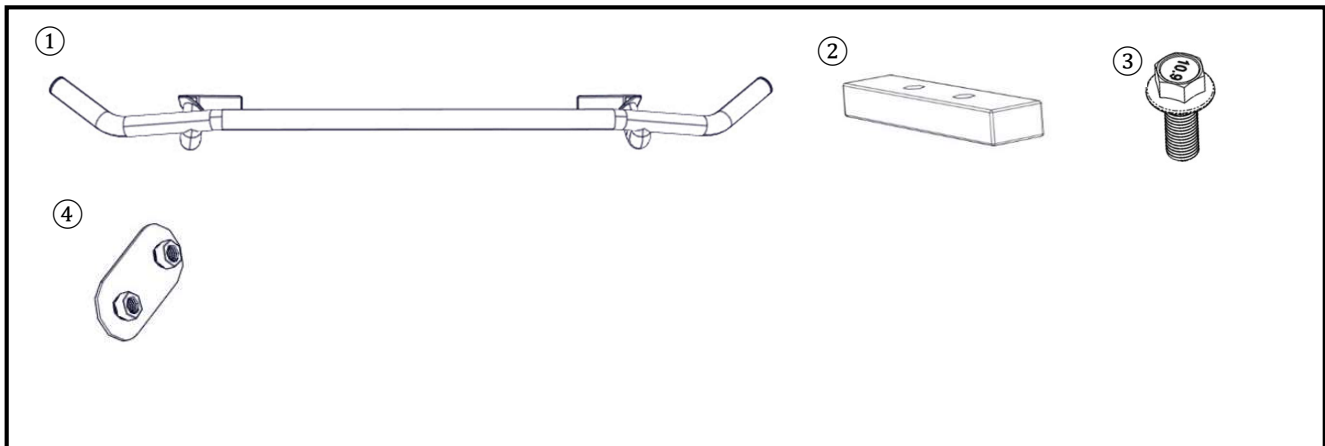

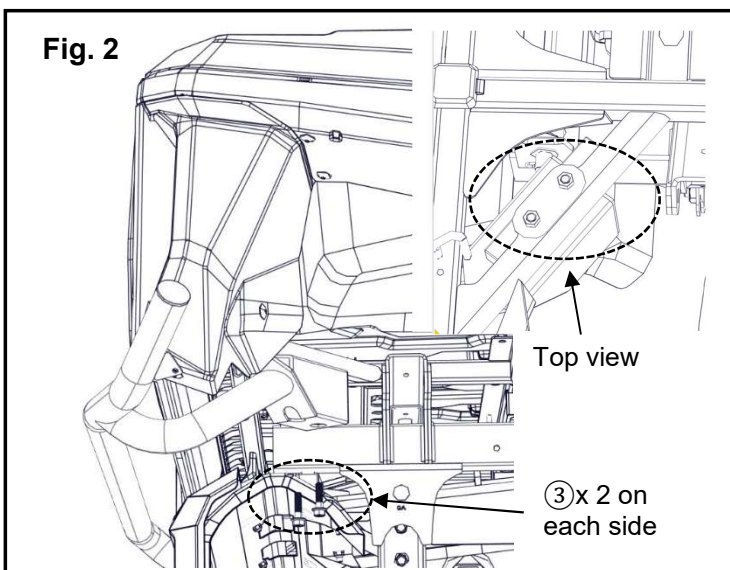
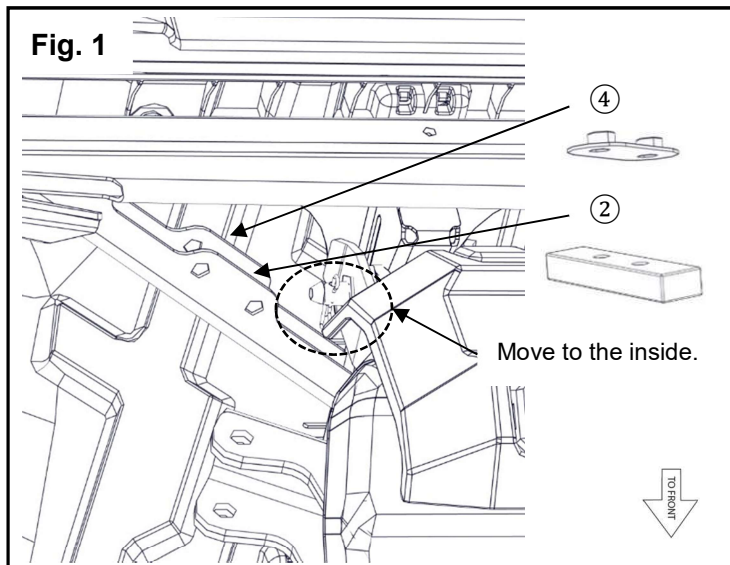

PREPARATION:

- Place the vehicle on a secure and level surface.
- Set the parking brake.
- Clean the mounting surfaces before beginning installation.
- Lock the bed in the lowered position.

INSTALLATION:

1. On the underside of the bed, locate the angled frame brackets above the muffler. Remove the cable tie holding the wire harness and move the wire harness aside.
2. The bed pivot pins may need to be moved to the inside to allow clearance for the brackets to fit. (Fig. 1)
3. Insert the ② Bracket Spacer inside the frame bracket and align the holes. (Fig. 1)
4. Place the ④ Weld Nut Plate on top of the frame and align the holes with the frame and ② Bracket Spacer. (Fig. 1)
5. Align the ① Carry Bar in position under the mounting locations.
Tip: You will need an assistant to hold the ① Carry bar in position until the bolts can be started. (Fig. 2)
6. Thread four ③ M8x30 Flanged Bolts into the ④ Weld Nut Plates. Start all four before threading them flush to the frame. Torque the four bolts to 25Nm (2.5 m-kg or 18.4 lb-ft).

MAINTENANCE:

Periodically, check torque on all hardware. If loose hardware is found, re-torque to specification.

CARE AND CLEANING:

Clean painted metal parts with a clean soft cloth and mild soap and water solution. Rinse and dry.

CUSTOMER SERVICE:

For further information see your Yamaha dealer.

ESTIMATED TIME TO INSTALL: 0.5 HRS.